



Johns Manville

PRODUCT DATA SHEET

Firetemp® CE Endothermic Caulk

Description

Firetemp® CE is a superior performance latex-based endothermic firestop caulk. It has excellent adhesion and bonding characteristics and will not slump or sag out after it has been properly installed. Firetemp® CE elastomeric caulk has been designed to stop the passage of fire, smoke and fumes through fire-rated assemblies after it has been fully cured. Firetemp® CE is chemically compatible with plastic pipes and cable jackets and is water resistant after cured. This cured seal provides a durable and flexible firestop and can be repaired if damaged or cut.

Applications

Firetemp® CE firestop caulk provides an effective firestop seal when used as a single or multiple component system for through penetrations and construction joints. It is commonly used on insulated and non-insulated metallic pipes and conduit; plastic supply and drain pipes; electrical cables and wires; cable trays and voids. Firetemp® CE exhibits excellent adhesion qualities with rated assemblies constructed of concrete, concrete block, wood, steel deck and gypsum wallboard.

- Metallic pipes and conduit (steel, copper, cast iron, stainless steel, EMT)
- Insulated pipes (fiberglass and AB/PVC tube insulation)
- Mechanical ducts
- Non-metallic pipes and conduit (ABS, CPVC, PVC, PEX, PE, FRPP, PP)
- Electrical cables and wires
- Communication wires
- Construction joints/gaps
 - Top -of -Wall
 - Horizontal and vertical joints
 - Perimeter floor joints

Advantages

When Firetemp® CE is exposed to high temperatures or direct fire, it releases water vapor, forms a solid char and retards the spread of fire.

Single Component

Firetemp® CE caulk can be used as a single

component firestop in many applications. Just install the caulk directly into the opening without using fibrous insulation materials. In many situations Firetemp® CE will replace the more conventional intumescent firestop devices such as pipe collars and wrap strips. This will reduce both the cost and installation time. To make certain installation is correct, consult manufacturer's current listings as well as Third Party published Fire Resistance Directories (Websites).

Firetemp® CE is packaged in conventional cartridges, foil packs (sausages) and 5-gallon pails. It can be applied using standard cartridge, sausage and reloadable caulking guns. Priming the surface is not necessary, however, cleaning the dust and debris off the surfaces before installation is recommended. The manufacturer recommends tooling the caulk after it has been installed. (see Section 2. Installation Instructions)

Versatility

Firetemp® CE adheres to dry and damp concrete, wood, metals and other common construction material surfaces to form an air and watertight bond. Firetemp® CE can be painted over using a latex-based paint after fully cured.

Flexibility

When Firetemp® CE is properly installed in construction joints it will allow up to 33 per cent extension and compression movement of the intersecting assemblies. It will also accommodate longitudinal and lateral movement of through and partial service penetrating items installed in the assembly. Firetemp® CE will remain flexible after it has fully cured.

System Testing, Standards, Requirements

Firetemp® CE has been Third Party tested for many firestop applications. They meet or exceed the requirements of ASTM E 814; ASTM E 119; UL 1479; UL 2079; ULC S 115-M95; ULC S 101; ASTM E 84. Underwriters Laboratories (UL) and ITS Warnock Hersey are Third Party fire endurance testing agencies accredited by ICBO,

Disclaimer: All technical advice, recommendations and services rendered by the seller are gratis. They are based on technical data which the seller believes to be reliable and are intended for use by persons having the skills and know how, at their own discretion and risk. In no event will the seller be liable for any consequential damages arising out of the use of this product.





Johns Manville

PRODUCT DATA SHEET

Firetemp® CE Endothermic Caulk

BOCA, and SBCCI in the United States and NBC in Canada.

Firetemp® CE caulk becomes an integral component in a complete building system of walls, floor/ceiling assemblies, service penetration items and joints. For this reason, its physical compatibility to other materials used in these complex configurations requires more than the standard firestopping product testing. The results of these additional tests are listed in Table 1, Firetemp® CE Caulk Test Data.

Firetemp® CE caulk has proven that it has all the physical and chemical characteristics desired in a firestopping product. After it has been installed and fully cured, it has excellent stability and flexibility even after four weeks at freezing temperatures of (minus) -15°F (-26°C) and exposed to extreme temperatures of 300°F (149°C) for 24 hours. Dimensional changes were well within the accepted standards (<2% per ASTM C 356). Dynamic testing has demonstrated the high elasticity properties of Firetemp® CE.

Installation Instructions

Firetemp® CE must be installed in compliance with the listed system designs published by third party testing laboratories (UL, ITS Warnock Hersey, Factory Mutual). Refer to their respective published Fire Resistance Directories or Websites. **Firetemp® CE** does not require mineral wool insulation in many applications. To install properly, remove excessive dust, dirt, debris, grease, oil and standing water. Apply caulking material with standard cartridge or bulk loading application guns or trowel into place with standard trowelling tools. Install the required amount of caulk material into the opening using sufficient pressure to ensure it is in contact with all surfaces, substrates and/or penetrating items. The manufacturer recommends tooling the surface of the installed caulking immediately with a moist putty knife or similar tooling utensil. Tooling the caulk material creates a stronger bond and a smoother finish especially when applied to irregular or porous surfaces. Do

not apply this product to mineral wool that is or was wet from exposure to water, standing water, rain or snow. For best results, installation temperatures should be 7°C - 32°C (45° - 90°F). The manufacturer recommends this product be installed by those trained in proper installation procedures (Approved Installer Card) and be able to read and understand a firestop system design listing (i.e. UL listing design).

Caution: Mineral wool may cause eye, skin or respiratory tract irritation. Avoid contact with eyes, skin or clothing. Recommend using gloves and goggles. Refer to Material Safety Data Sheets published by mineral wool manufacturers.

Limitations

This product cures naturally through the evaporation of its water content and is water resistant after fully cured. Exposure to rain, running or standing water before the sealant is fully cured may cause the installed material(s) to wash out. This product is not designed to be a waterproof seal and should not be installed where there will be constant wet conditions nor immersed in water continuously. Refer to Water Resistance, Table 1.

Availability

10.1 oz (300ml) plastic cartridge
20 oz (600ml) foil (sausage) pack
29 oz (850ml) jumbo cartridge
5 gallon (18.9L) plastic tapered pails
(12 cartridges/sausages per box)

Coverage

Estimated product usage will vary depending on opening size and configuration. Check Firetemp® estimating charts for coverage.

Technical Services

For technical information and assistance regarding application information, code requirements and performance specifications, call 1-888-322-1129. If this document is more than one year old, contact Johns Manville for current information.

Disclaimer: All technical advice, recommendations and services rendered by the seller are gratis. They are based on technical data which the seller believes to be reliable and are intended for use by persons having the skills and know how, at their own discretion and risk. In no event will the seller be liable for any consequential damages arising out of the use of this product.





Johns Manville

PRODUCT DATA SHEET

Firetemp® CE Endothermic Caulk

Table 1

Physical and Chemical Properties

Type	Waterborne Resin
Color	Rust Red
Odor	Mild Latex
Solids Content (Wt%)	77± 2%
pH (ASTM E-70)	8 - 9
Specific Gravity: (ASTM D 1475)	1.40 - 1.50
Viscosity (ASTM D-2196)	560,000-744,000 cps
Application Temperature	7°C - 32°C (45°F - 90°F)
Drying Time (ASTM D-1640)	
• Dry to touch @ 6 mils:	20-30 minutes
• Cure time (depending on thickness and environment)	7-21 days
In Service Temperature	up to 49°C(120°F)
Full Cure and Adhesion (at 25°C and 50% R.H.)	7-21 days
Elongation (ASTMD-2370)	1400%
Tensile Strength (ASTM D 2370)	26 psi
Slump (ASTM D-2202 modified)	Passed
Freeze-Thaw (ASTM D-2243)	Excellent
Extrudability (ASTM C-731)	Passed
Volume Shrinkage (ASTM C-1241)	Passed
Flame Spread	Less than 25
Smoke Development	Less than 50
Hardness (ASTM D-2240 Shore A)	22
Fungus Resistance (ASTM C 1338-00)	Passed
Combustion Product Toxicity (ASTM E 800)	Passed
STC Sound Transmission Loss (ASTM E 90-99)	Full Recovery
Corrosion (ASTM C 655) (for steel, copper, aluminum, galvanized steel and stainless steel)	Passed
Water Resistance (28 day Solubility Loss)	3%
Corrosion Resistance ASTM B-117) Salt Spray	Passed

Typical Concrete Penetrations

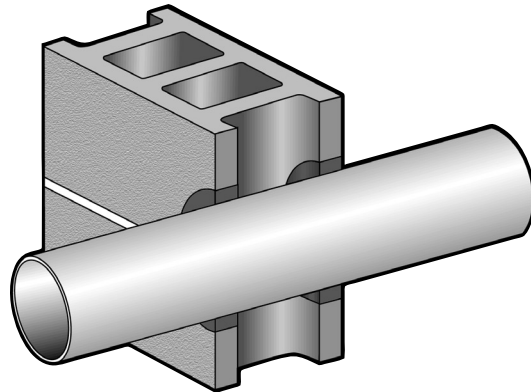

Typical Pipe Penetrations

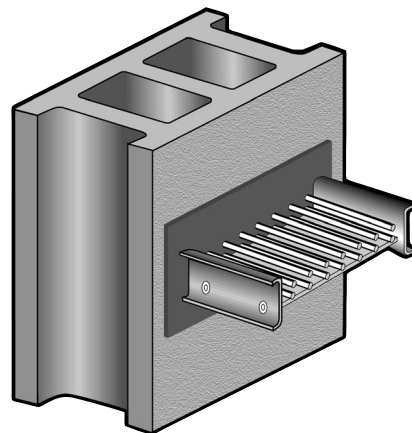

Typical Cable Penetrations

Disclaimer: All technical advice, recommendations and services rendered by the seller are gratis. They are based on technical data which the seller believes to be reliable and are intended for use by persons having the skills and know how, at their own discretion and risk. In no event will the seller be liable for any consequential damages arising out of the use of this product.



Section 1 - Chemical Product and Company Identification**Product Name** Firetemp® Firestop CE and SE**CAS#** Mixture**Generic Name** Coating (Latex)**Formula** Mixture**Chemical Name:** Mixture**Hazard Label** L2104**Manufacturer Information**

Johns Manville Insulation Group

Fire Protection Systems

P.O. Box 5108

Denver, CO 80127

Telephone: 303-978-2000

Internet Address: <http://www.jm.com>

Emergency: 800-424-9300 (Chemtrec)

Trade Names: Firetemp® Firestop CE, SE**Section 2 - Composition / Information on Ingredients**

CAS #	Component	Percent
1317-65-3	Calcium carbonate	45-65
7732-18-5	Water	15-35
Proprietary	Vinyl acetate polymer	15-25
Proprietary	Modified acrylic polymer	0-10
13463-67-7	Titanium dioxide	<2
57-55-6	1,2-Propylene glycol	1-2
1309-37-1	Iron oxide	<0.3
108-05-4	Vinyl acetate monomer	<0.2
1317-61-9	Ferric oxide black	<0.1
50-00-0	Formaldehyde (Trace)	<0.004

Additional Component Information

Note: Due to the product form, exposures to hazardous dusts or fumes will not occur. Exposure limits are given for reference only.

Section 3 - Hazards Identification**Emergency Overview**

APPEARANCE AND ODOR: Caulk (CE): red. Mastic spray (SE): gray. Mild odor.

Under normal conditions of use, this product is not expected to create any unusual emergency hazards.

In the event of fire, use normal fire fighting procedures to prevent inhalation of smoke and gases.

Potential Health Effects**Summary**

Due to the form of the product hazardous exposures are unlikely to occur. Exposure may cause slight temporary irritation to skin and eyes in some individuals.

Inhalation

Not applicable

Skin

Temporary irritation may occur.

Absorption

Not applicable

Ingestion

This product is not intended to be ingested or eaten under normal conditions of use. If ingested, it may cause temporary irritation to the gastrointestinal (GI) tract, especially the stomach.

Eyes

Temporary irritation (itching) or redness may occur.

Target Organs

Skin and eyes.

Primary Routes of Entry (Exposure)

Skin and eyes.

Medical Conditions Aggravated by Exposure

None identified.

Section 4 - First Aid Measures

First Aid: Inhalation

Remove to fresh air. If symptoms persist contact a physician.

First Aid: Skin

Wash exposed skin with soap and water. If irritation develops or persists, seek medical attention. Wash contaminated clothing before reuse.

First Aid: Ingestion

This product is not intended to be ingested or eaten. If this product is ingested, do not induce vomiting. Drink plenty of water. Contact a physician immediately.

First Aid: Eyes

Flush eyes with large amounts of water for 5-20 minutes. Contact a medical professional.

First Aid: Notes to Physician

Remove the source of irritation and treat symptoms as necessary.

Section 5 - Fire Fighting Measures

Flash Point: Not applicable

Upper Flammable Limit (UFL): Not applicable

Auto Ignition: Not determined

Rate of Burning: Not determined

General Fire Hazards

There is no potential for fire or explosion.

Hazardous Combustion Products

Dried films forced to burn may release: Carbon dioxide, carbon monoxide and other hydrocarbon oxidation products. The exact composition will depend on the conditions of combustion.

Extinguishing Media

Use any media suitable for the surrounding fires.

Fire Fighting Equipment/Instructions

No special procedures are expected to be necessary for this product. Normal fire fighting procedures should be followed to avoid inhalation of smoke and gases.

Method Used: Not applicable

Lower Flammable Limit (LFL): Not applicable

Flammability Classification: Not determined

Section 6 - Accidental Release Measures

Containment Procedures

Clean-Up Procedures

Wastes are not hazardous as defined by the Resource Conservation and Recovery Act (RCRA; 40 CFR 261). Comply with state and local regulations for disposal of these products. If you are unsure of the regulations, contact your local Public Health Department, or the local office of the Environmental Protection Agency (EPA).

Section 7 - Handling and Storage

Handling Procedures

Use protective equipment as described in Section 8 of this material safety data sheet when handling uncontained material.

Storage Procedures

Material should be kept cool and dry, and protected from the elements. Store in tightly closed containers to prevent contamination. Store at temperatures between 4°-35°C/40°-95°F. Keep away from excess heat. Do not freeze.

Section 8 - Exposure Controls / Personal Protection

Exposure Guidelines

A: General Product Information

No information available for the product.

B: Component Exposure Limits

Calcium carbonate (1317-65-3)

ACGIH: 10 mg/m³ TWA (The value is for particulate matter containing no asbestos and <1% crystalline silica)

OSHA: 15 mg/m³ TWA (total dust); 5 mg/m³ TWA (respirable fraction)

Titanium dioxide (13463-67-7)

ACGIH: 10 mg/m³ TWA

OSHA: 10 mg/m³ TWA (total dust)

Iron oxide (1309-37-1)

ACGIH: 5 mg/m³ TWA (as Fe, welding fumes, dust, total particulate)

OSHA: 10 mg/m³ TWA (fume)

Vinyl acetate monomer (108-05-4)

ACGIH: 10 ppm TWA

15 ppm STEL

OSHA: 10 ppm TWA; 30 mg/m³ TWA

20 ppm STEL; 60 mg/m³ STEL

Formaldehyde (Trace) (50-00-0)

ACGIH: 0.3 ppm Ceiling

OSHA: 0.75 ppm TWA PEL; 2 ppm STEL; 0.5 ppm TWA action level; Irritant and potential cancer hazard (29 CFR 1910.1048)

PERSONAL PROTECTIVE EQUIPMENT

Personal Protective Equipment: Eyes/Face

Safety glasses with sideshields, chemical goggles, or face mask recommended.

Personal Protective Equipment: Skin

Any chemical impervious glove may be used to protect skin.

Personal Protective Equipment: Respiratory

Not applicable

Ventilation

Local exhaust or general dilution ventilation should be provided to keep exposure levels below the applicable exposure limits.

Personal Protective Equipment: General

To protect skin from contact with product: Long sleeved shirts and long pants are recommended.

Section 9 - Physical & Chemical Properties

Appearance:	Caulk-red; Spray-Grey	Odor:	Slightly aromatic
Physical State:	semi-solid	pH:	8-9
Vapor Pressure:	18.51	Vapor Density:	>1
Boiling Point:	>100 C	Melting Point:	Not applicable
Solubility (H₂O):	Not determined	Specific Gravity:	1.4-1.5, Caulk; 1.15-1.35 Spray (25°C)
Freezing Point:	0	Evaporation Rate:	<1
Viscosity:	560,000-744,000 (caulk), 50,000-60,000 (spray) cps	Percent Volatile:	Not determined
VOC:	53.9 (caulk), 81.3 (spray)		

Section 10 - Chemical Stability & Reactivity Information

Chemical Stability

This is a stable material. This product is not reactive.

Hazardous Decomposition

Dried films forced to burn may release: Carbon dioxide, carbon monoxide and other hydrocarbon oxidation products. The exact composition will depend on the conditions of combustion.

Hazardous Polymerization

Will not occur.

Section 11 - Toxicological Information**Acute Toxicity****A: General Product Information**

Skin and eye irritation may occur after contact with product.

B: Component Analysis - LD50/LC50**1,2-Propylene glycol (57-55-6)**

Oral LD50 Rat: 20 gm/kg

Oral LD50 Mouse: 22 gm/kg

Dermal LD50 Rabbit: 20800 mg/kg

Vinyl acetate monomer (108-05-4)

Inhalation LC50 Rat: 11400 mg/m³/4H

Inhalation LC50 Mouse: 1550 ppm/4H

Oral LD50 Rat: 2920 mg/kg

Oral LD50 Mouse: 1613 mg/kg

Dermal LD50 Rabbit: 2335 mg/kg

Formaldehyde (Trace) (50-00-0)

Inhalation LC50 Rat: 203 mg/m³

Inhalation LC50 Mouse: 454 mg/m³/4H

Oral LD50 Rat: 100 mg/kg

Oral LD50 Mouse: 42 mg/kg

Dermal LD50 Rabbit: 270 uL/kg

Carcinogenicity**A: General Product Information**

The Occupational Safety and Health Administration (OSHA), National Toxicology Program (NTP), International Agency for Research on Cancer (IARC), and American Conference of Governmental Industrial Hygienists (ACGIH) have not classified this product in its entirety as a carcinogen.

B: Component Carcinogenicity**Titanium dioxide (13463-67-7)**

ACGIH: A4 - Not Classifiable as a Human Carcinogen

IARC: Monograph 47, 1989 (Group 3 (not classifiable))

Iron oxide (1309-37-1)

ACGIH: A4 - Not Classifiable as a Human Carcinogen (dust and fume, as Fe)

IARC: Supplement 7, 1987; Monograph 1, 1972 (Group 3 (not classifiable))

Vinyl acetate monomer (108-05-4)

ACGIH: A3 - Animal Carcinogen

IARC: Monograph 63, 1995 (Group 2B (possibly carcinogenic to humans))

Formaldehyde (Trace) (50-00-0)

ACGIH: A2 - Suspected Human Carcinogen

OSHA: 0.75 ppm TWA PEL; 2 ppm STEL; 0.5 ppm TWA action level; Irritant and potential cancer hazard (29 CFR 1910.1048)

NTP: Suspect Carcinogen (Possible Select Carcinogen)

IARC: Monograph 62, 1995 (Group 2A (probably carcinogenic to humans))

Chronic Toxicity

Vinyl acetate is identified by IARC as a potential carcinogen based on testing in animals. However, there is no published evidence that it has caused cancer in humans.

Section 12 - Ecological Information**Ecotoxicity****A: General Product Information**

No information available for the product.

B: Component Analysis - Ecotoxicity - Aquatic Toxicity**1,2-Propylene glycol (57-55-6)**

LC50 (24 hr) goldfish:>5000 mg/L.; LC50 (48 hr) guppy:>10000 mg/L.:

EC50 (30 min) Photobacterium phosphoreum: 710 mg/L:

EC50 (48 hr) water flea:>10000 mg/L.:

Vinyl acetate monomer (108-05-4)

LC50 (96 hr) fathead minnow: 31.0 mg/L.; LC50 (96 hr) bluegill: 31.0 mg/L.; LC50 (96 hr) goldfish: 31.0 mg/L.:

EC50 (24 hr) water flea: 52.0 mg/L.:

Formaldehyde (Trace) (50-00-0)

LC50 (96 hr) fathead minnow: 24.1 mg/L: Flow-through, 21.7 degrees C, pH 6.8, 50.8 mg/L CaCO3.; LC50 (96 hr) bluegill: 0.10 mg/L: Flow-through.

EC50 (30 min) Photobacterium phosphoreum: 3.00-10.2 mg/L:

EC50 (96 hr) water flea: 20 mg/L.:

Section 13 - Disposal Considerations**US EPA Waste Number & Descriptions****A: General Product Information**

The U.S. Environmental Protection Agency (EPA) under Resource Conservation and Recovery Act (RCRA) regulations does not regulate this product as a hazardous waste.

B: Component Waste Numbers**Formaldehyde (Trace) (50-00-0)**

RCRA: waste number U122

Disposal Instructions

Dispose of waste material according to Local, State, Federal, and Provincial Environmental Regulations.

Section 14 - Transportation Information**US DOT Information**

Shipping Name: This product is not classified as a hazardous material for transport.

Section 15 - Regulatory Information**US Federal Regulations****A: General Product Information**

No information available for the product.

B: Component Analysis

This material contains one or more of the following chemicals required to be identified under SARA Section 302 (40 CFR 355 Appendix A), SARA Section 313 (40 CFR 372.65) and/or CERCLA (40 CFR 302.4).

Vinyl acetate monomer (108-05-4)

SARA 302: TPQ = 1000 pounds; RQ = 5000 pounds

SARA 313: form R reporting required for 0.1% de minimis concentration

CERCLA: final RQ = 5000 pounds (2270 kg)

Formaldehyde (Trace) (50-00-0)

SARA 302: TPQ = 500 pounds; RQ = 100 pounds (does not meet toxicity criteria but because of high production volume and recognized toxicity is considered a chemical of concern)

CERCLA: final RQ = 100 pounds (45.4 kg)

State Regulations**A: General Product Information**

No information available for the product.

B: Component Analysis - State

The following components appear on one or more of the following state hazardous substances lists:

Component	CAS #	CA	FL	MA	MN	NJ	PA
Calcium carbonate	1317-65-3	No	No	Yes	Yes	No	Yes
Titanium dioxide	13463-67-7	No	No	Yes	Yes	Yes	Yes
1,2-Propylene glycol	57-55-6	No	No	No	Yes	No	Yes
Iron oxide	1309-37-1	Yes	Yes	Yes	Yes	Yes	Yes
Vinyl acetate monomer	108-05-4	Yes	Yes	Yes	Yes	Yes	Yes
Formaldehyde (Trace)	50-00-0	Yes	Yes	Yes	Yes	Yes	Yes

The following statement(s) are provided under the California Safe Drinking Water and Toxic Enforcement Act of 1986 (Proposition 65):
WARNING! This product contains a chemical known to the state of California to cause cancer.

Other Regulatory Information**A: General Product Information**

No information available for the product.

B: TSCA Status

This product and its components are listed on the TSCA 8(b) inventory.

None of the components listed in this product are listed on the TSCA Export Notification 12(b) list.

C: Component Analysis - Inventory

Component	CAS #	TSCA	DSL	EINECS
Calcium carbonate	1317-65-3	Yes	No	Yes
Water	7732-18-5	Yes	Yes	Yes
Titanium dioxide	13463-67-7	Yes	Yes	Yes
1,2-Propylene glycol	57-55-6	Yes	Yes	Yes
Iron oxide	1309-37-1	Yes	Yes	Yes
Vinyl acetate monomer	108-05-4	Yes	Yes	Yes
Ferric oxide black	1317-61-9	Yes	Yes	Yes
Formaldehyde (Trace)	50-00-0	Yes	Yes	Yes

Component Analysis - WHMIS IDL

The following components are identified under the Canadian Hazardous Products Act Ingredient Disclosure List:

Component	CAS #	Minimum Concentration
1,2-Propylene glycol	57-55-6	1%; English Item 1362; French Item 1454

Section 16 - Other Information

Other Information

Prepared for:
Johns Manville Insulation Group
Fire Protection Systems
P.O. Box 5108
Denver, CO 80217-5108

Prepared by:
Johns Manville Technical Center
P.O. Box 625005
Littleton, CO USA 80162-5005

As of the date of preparation of this document, the foregoing information is believed to be accurate and is provided in good faith to comply with applicable federal and state law(s). However, no warranty or representation with respect to such information is intended or given.

Material Name: Firetemp® Firestop CE and SE

**Material Safety Data
Sheet ID: 2104**

Date	MSDS #	Reason
05/23/02	2104-1.0000	Moved SE and CE from 2100 to new MSDS 2104; updated formulation.

This is the end of MSDS # 2104