



PRODUCT DATA SHEET

Firetemp® SI Intumescent Spray

Description

Firetemp® SI spray is a latex-based, intumescent spray designed to stop the passage of fire, smoke, and fumes through fire-rated separations. Firetemp® SI spray forms a durable and flexible seal after curing.

Applications

Firetemp® SI spray provides an effective firestop for joint assemblies, such as floor, floor to wall, wall, head of wall, bottom of wall, steel decking to wall, curtain wall to slab edge, and some through penetrations, in any combination of wood, concrete, concrete block, steel and gypsum materials.

Advantages

Intumescent. When exposed to high temperatures or fire, Firetemp® SI spray expands in volume to quickly close off voids and stop fire, smoke, and heat.

System Design

For small joints, Firetemp® SI spray can be used alone, as a single component system. For large joints, Firetemp® SI spray is designed to be used in a multiple-component system with mineral wool. This combination maximizes the firestopping properties.

Installation

Firetemp® SI spray is installed with commercial power spray equipment. Priming is not required before use.

Versatility

Firetemp® SI spray adheres easily to dry or damp concrete, wood, metal, and other common building material surfaces.

Flexibility

Firetemp® SI spray accommodates up to 33 percent joint movement compression/extension. It remains flexible and fully resistant to water after curing.

Compliance

Firetemp® SI spray has been tested for various types of firestop installations and meets or exceeds the requirements of ASTM E 814, ASTM E 119, UL 1479, UL 2079, CAN/ULC S115, and CAN/ULC S101. Underwriters Laboratories (UL) is a third party, fire endurance testing agency accredited by ICBO, BOCA and SBCCI (National Evaluation Services) in the United States. All joint firestopping tests included dynamic use (up to 33% movement) in accordance with ICBO ESAC 30 for a total of 500 cycles.

Firetemp® SI spray becomes an integral component in a complete building system of walls, floors, and ceilings. For this reason, its physical compatibility to other products used in these complex configurations requires more than the routine firestopping product testing. The results of these additional tests are listed in Table 1. Firetemp® SI Spray Test Data.

Firetemp® SI spray has proven that it has all of the physical characteristics desired in a firestopping product. Once installed and cured, it has excellent stability, even after four weeks at freezing temperatures of -15°F (-26°C) and exposure to extreme temperatures of 300°F (149°C) for 24 hours. Dimensional changes were well within the accepted standards (<2% per ASTM C 356). Dynamic testing has demonstrated Firetemp® SI spray's highly elastic properties.

When tested in simulated fire conditions, this intumescent spray expanded uniformly, to at least eight times its original volume, without causing failure to other components. When tested per ASTM E 84, the flame spread was <25 and smoke developed was <50.

Corrosion and microbial growth were tested using procedures outlined in ASTM C 665. Firetemp® SI spray does not promote the

Disclaimer: All technical advice, recommendations and services rendered by the seller are gratis. They are based on technical data which the seller believes to be reliable and are intended for use by persons having the skills and know how, at their own discretion and risk. In no event will the seller be liable for any consequential damages arising out of the use of this product.





PRODUCT DATA SHEET Firetemp® SI Intumescent Spray

corrosion of steel, copper, or aluminum, but may cause discoloration on galvanized metal surfaces. Also, Firetemp® SI spray does not support mold growth.

The use of Firetemp® SI spray will restore the acoustical performance level (STC rating) to firewall systems used in standard building construction when tested according to ASTM E 90-90.

Available Forms

Firetemp® SI spray is supplied in 5 gal. (18.9 L) plastic pails.

Availability

5 Gallon (18.9L) plastic tapered pails

Coverage

Estimated product coverage is 25 square feet (2.3 sq. m) per gallon (3.78 L) when applied to a

thickness of 1/16 inch (1.6 mm). For specific configurations check estimating chart.

Coverage

For technical information and assistance regarding application information, code approvals and performance specifications, call 1-888-322-1129. Outside of the USA and in Canada, call (604) 515-1788. If this piece is more than one year old, please contact Johns Manville for the current information.

Technical Services

For technical information and assistance regarding application information, code requirements and performance specifications, call 1-888-322-1129. If this document is more than one year old, contact Johns Manville for current information.

Disclaimer: All technical advice, recommendations and services rendered by the seller are gratis. They are based on technical data which the seller believes to be reliable and are intended for use by persons having the skills and know how, at their own discretion and risk. In no event will the seller be liable for any consequential damages arising out of the use of this product.



PRODUCT DATA SHEET
Firetemp® SI Intumescent Spray

Table 1, Firetemp®SI Spray Test Data

Property	Firetemp®SI Spray
Density	80-100pcf
PH	8
Viscosity	36,000
Moisture Absorption (Wt%)	<4%
Solids Content (Wt%)	75%
Elasticity	up to 33%
Intumescence	1200%
UV Resistance (QEV High Intensity Cycle)	
1500 hrs, 200 cycles	Pass
Stability (dimension, cracks, blisters, exfoliation, flexibility)	
Freezing: -15°F (-26°C), 28 days	Pass
75-120°F (24-49°C), 28 days	Pass
200°F (93°C), 24 hours	Pass
300°F (149°C), 24 hours	Pass
Dimensional Change	
Freezing: -120°F (-84°C), 28 Days	Passed
300°F (149°C), 24 hours	Passed
Corrosion (ASTM C 665)	Pass
Steel	Pass
Copper	Pass
Aluminum	Pass
Stress Corrosion Cracking for Austenitic	
Stainless Steel (ASTM C 692)	Passed
Microbial Growth (ASTM C 665)	Pass
Surface Burning Characteristics (ASTM E 84)	
Flame	10
Smoke	10
Smoke Toxicity NBS Chamber (ASTM E 800)	Pass
STC Breached Wall Recovery (full, partial, none) (ASTM E 90-90)	Full

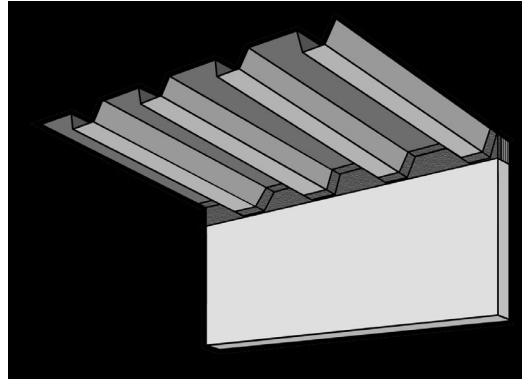

Typical Top of Wall Joint

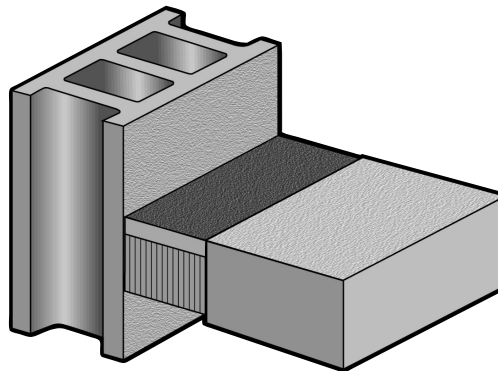

Typical Wall and Floor Joint

Disclaimer: All technical advice, recommendations and services rendered by the seller are gratis. They are based on technical data which the seller believes to be reliable and are intended for use by persons having the skills and know how, at their own discretion and risk. In no event will the seller be liable for any consequential damages arising out of the use of this product.



Section 1 - Chemical Product and Company Identification**Product Name** Firetemp® Firestop**CAS#** Mixture**Generic Name** Coating (Latex)**Formula** Mixture**Chemical Name:** Mixture**Hazard Label** L2100**Manufacturer Information**

Johns Manville Insulation Group

Fire Protection Systems

P.O. Box 5108

Denver, CO 80127

Telephone: 303-978-2000

Internet Address: <http://www.jm.com>

Emergency: 800-424-9300 (Chemtrec)

Trade Names: Firetemp® Firestop (CI, SI)**Section 2 - Composition / Information on Ingredients**

CAS #	Component	Percent
Proprietary	Vinyl acrylic copolymer	35-65
1317-65-3	Calcium carbonate	25-50
7732-18-5	Water	15-30
7782-42-5	Graphite	3-15
57-55-6	1,2-Propylene glycol	0.5-5
13463-67-7	Titanium dioxide	<1
1309-37-1	Iron oxide	<0.5
Not Available	Blue pigment	<0.1
1317-61-9	Ferric oxide black	<0.1

Additional Component Information

Note: Due to the product form, exposures to hazardous dusts or fumes will not occur. Exposure limits are given for reference only.

Section 3 - Hazards Identification**Emergency Overview**

APPEARANCE AND ODOR: Caulk: red. Spray Mastic: Light blue.

Under normal conditions of use, this product is not expected to create any unusual emergency hazards.

In the event of fire, use normal fire fighting procedures to prevent inhalation of smoke and gases.

Potential Health Effects**Summary**

Due to the form of the product hazardous exposures are unlikely to occur. Exposure may cause slight temporary irritation to skin and eyes in some individuals.

Inhalation

Not applicable

Skin

Temporary irritation may occur.

Absorption

Not applicable

Ingestion

This product is not intended to be ingested or eaten under normal conditions of use. If ingested, it may cause temporary irritation to the gastrointestinal (GI) tract, especially the stomach.

Eyes

Temporary irritation (itching) or redness may occur.

Target Organs

Skin and eyes.

Primary Routes of Entry (Exposure)

Skin and eyes.

Medical Conditions Aggravated by Exposure

None identified.

Section 4 - First Aid Measures

First Aid: Inhalation

Not applicable

First Aid: Skin

Remove contaminated clothing. Wash exposed skin with soap and cold water. Launder contaminated clothing before reusing.

First Aid: Ingestion

This product is not intended to be ingested or eaten. If this product is ingested, do not induce vomiting. Drink plenty of water. Contact a physician immediately.

First Aid: Eyes

Flush eyes with large amounts of water for 5-20 minutes. Contact a medical professional.

First Aid: Notes to Physician

Treat symptomatically. Emesis may be indicated in recent (within 30 minutes) ingestion of large quantities.

Section 5 - Fire Fighting Measures

Flash Point: Not applicable

Upper Flammable Limit (UFL): Not applicable

Auto Ignition: Not determined

Rate of Burning: Not determined

General Fire Hazards

There is no potential for fire or explosion.

Hazardous Combustion Products

Carbon monoxide, carbon dioxide, aliphatic hydrocarbons, hydrocarbon oxidation products including aldehydes and alcohols, nitrogen oxidation products, hydrogen fluoride, hydrogen cyanide, and sulfur oxides.

Extinguishing Media

Use any media suitable for the surrounding fires.

Fire Fighting Equipment/Instructions

Firefighters should wear full-face, self contained breathing apparatus and impervious protective clothing. Firefighters should avoid inhaling any combustion products.

Section 6 - Accidental Release Measures

Containment Procedures

Clean-Up Procedures

Wastes are not hazardous as defined by the Resource Conservation and Recovery Act (RCRA; 40 CFR 261). Comply with state and local regulations for disposal of these products. If you are unsure of the regulations, contact your local Public Health Department, or the local office of the Environmental Protection Agency (EPA).

Section 7 - Handling and Storage

Handling Procedures

Use protective equipment as described in Section 8 of this material safety data sheet when handling uncontained material.

Storage Procedures

Material should be kept cool and dry, and protected from the elements. Store in tightly closed containers to prevent contamination. Store at temperatures between 4°-35°C/40°-95°F. Keep away from excess heat. Do not freeze. Warehouse storage should be in accordance with package directions, if any.

Section 8 - Exposure Controls / Personal Protection

Exposure Guidelines

A: General Product Information

No information available for the product.

B: Component Exposure Limits

Calcium carbonate (1317-65-3)

ACGIH: 10 mg/m³ TWA (The value is for particulate matter containing no asbestos and <1% crystalline silica)

OSHA: 15 mg/m³ TWA (total dust); 5 mg/m³ TWA (respirable fraction)

Graphite (7782-42-5)

ACGIH: 2 mg/m³ TWA (respirable fraction, all forms except graphite fibers)

OSHA: 2.5 mg/m³ TWA (respirable dust)

Titanium dioxide (13463-67-7)

ACGIH: 10 mg/m³ TWA

OSHA: 10 mg/m³ TWA (total dust)

Iron oxide (1309-37-1)

ACGIH: 5 mg/m³ TWA (as Fe, welding fumes, dust, total particulate)

OSHA: 10 mg/m³ TWA (fume)

PERSONAL PROTECTIVE EQUIPMENT

Personal Protective Equipment: Eyes/Face

Safety glasses with sideshields, chemical goggles, or face mask recommended.

Personal Protective Equipment: Skin

Any chemical impervious glove may be used to protect skin.

Personal Protective Equipment: Respiratory

Not applicable

Ventilation

Not applicable

Personal Protective Equipment: General

Impervious apron or coveralls can be used to protect clothing.

Section 9 - Physical & Chemical Properties

Appearance: Caulk: Red. Spray Mastic: Light blue.	Odor: No specific odor
Physical State: semi-solid	pH: 7-8.9
Vapor Pressure: Not determined	Vapor Density: >1
Boiling Point: Not applicable	Melting Point: Not applicable
Solubility (H₂O): Not determined	Specific Gravity: >1.37-1.47 Caulk; 1.27-1.37 Spray (25°C)
Freezing Point: Not determined	Evaporation Rate: <1
Viscosity: 288,000-464,000 (caulk); 24,000-48,000 (spray)	Percent Volatile: Not determined
VOC: Not determined	

Section 10 - Chemical Stability & Reactivity Information

Chemical Stability

This is a stable material. This product is not reactive.

Hazardous Decomposition

Dried films forced to burn will produce: Carbon monoxide, carbon dioxide, aliphatic hydrocarbons, hydrocarbon oxidation products including aldehydes and alcohols, nitrogen oxidation products, hydrogen fluoride, hydrogen cyanide, and sulfur oxides.

Hazardous Polymerization

Will not occur.

Section 11 - Toxicological Information

Acute Toxicity

A: General Product Information

Skin and eye irritation may occur after contact with product.

B: Component Analysis - LD50/LC50

1,2-Propylene glycol (57-55-6)

Oral LD50 Rat : 20 gm/kg

Oral LD50 Mouse : 22 gm/kg

Dermal LD50 Rabbit : 20800 mg/kg

Carcinogenicity

A: General Product Information

The Occupational Safety and Health Administration (OSHA), National Toxicology Program (NTP), International Agency for Research on Cancer (IARC), and American Conference of Governmental Industrial Hygienists (ACGIH) have not classified this product in its entirety as a carcinogen.

B: Component Carcinogenicity

Titanium dioxide (13463-67-7)

ACGIH: A4 - Not Classifiable as a Human Carcinogen

IARC: Monograph 47, 1989 (Group 3 (not classifiable))

Iron oxide (1309-37-1)

ACGIH: A4 - Not Classifiable as a Human Carcinogen (dust and fume, as Fe)

IARC: Supplement 7, 1987; Monograph 1, 1972 (Group 3 (not classifiable))

Chronic Toxicity

None identified.

Section 12 - Ecological Information

Ecotoxicity

A: General Product Information

No information available for the product.

B: Component Analysis - Ecotoxicity - Aquatic Toxicity

1,2-Propylene glycol (57-55-6)

LC50 (24 hr) goldfish:>5000 mg/L.;LC50 (48 hr) guppy:>10000 mg/L.:

EC50 (30 min) Photobacterium phosphoreum:710 mg/L:

EC50 (48 hr) water flea:>10000 mg/L.:

Section 13 - Disposal Considerations

US EPA Waste Number & Descriptions

A: General Product Information

This product is not regulated as a hazardous waste by the U.S. Environmental Protection Agency (EPA) under Resource Conservation and Recovery Act (RCRA) regulations.

B: Component Waste Numbers

No EPA Waste Numbers are applicable for this product's components.

Disposal Instructions

Dispose of waste material according to Local, State, Federal, and Provincial Environmental Regulations.

Section 14 - Transportation Information

US DOT Information

Shipping Name: This product is not classified as a hazardous material for transport.

Section 15 - Regulatory Information
--

US Federal Regulations**A: General Product Information**

No information available for the product.

B: Component Analysis

None of this products components are listed under SARA Section 302 (40 CFR 355 Appendix A), SARA Section 313 (40 CFR 372.65), or CERCLA (40 CFR 302.4).

State Regulations**A: General Product Information**

No information available for the product.

B: Component Analysis - State

The following components appear on one or more of the following state hazardous substances lists:

Component	CAS #	CA	FL	MA	MN	NJ	PA
Calcium carbonate	1317-65-3	No	No	Yes	Yes	No	Yes
Graphite	7782-42-5	Yes	Yes	Yes	Yes	No	Yes
1,2-Propylene glycol	57-55-6	No	No	No	Yes	No	Yes
Titanium dioxide	13463-67-7	No	No	Yes	Yes	Yes	Yes
Iron oxide	1309-37-1	Yes	Yes	Yes	Yes	Yes	Yes

Other Regulatory Information**A: General Product Information**

No information available for the product.

B: TSCA Status

This product and its components are listed on the TSCA 8(b) inventory.

None of the components listed in this product are listed on the TSCA Export Notification 12(b) list.

C: Component Analysis - Inventory

Component	CAS #	TSCA	DSL	EINECS
Calcium carbonate	1317-65-3	Yes	No	Yes
Water	7732-18-5	Yes	Yes	Yes
Graphite	7782-42-5	Yes	Yes	Yes
1,2-Propylene glycol	57-55-6	Yes	Yes	Yes
Titanium dioxide	13463-67-7	Yes	Yes	Yes
Iron oxide	1309-37-1	Yes	Yes	Yes
Ferric oxide black	1317-61-9	Yes	Yes	Yes

Component Analysis - WHMIS IDL

The following components are identified under the Canadian Hazardous Products Act Ingredient Disclosure List:

Component	CAS #	Minimum Concentration
1,2-Propylene glycol	57-55-6	1%; English Item 1362; French Item 1454

Section 16 - Other Information

Other Information

Prepared for:
Johns Manville Insulation Group
Fire Protection Systems
P.O. Box 5108
Denver, CO 80217-5108

Prepared by:
Johns Manville Technical Center
P.O. Box 625005
Littleton, CO USA 80162-5005

As of the date of preparation of this document, the foregoing information is believed to be accurate and is provided in good faith to comply with applicable federal and state law(s). However, no warranty or representation with respect to such information is intended or given.

Date	MSDS #	Reason
08/01/00	2100-1.0000	New MSDS authoring system.
08/17/00	2100-2.0000	Trade Names: Added CE; changed Firetemp™ to Firetemp®. Sect. 2: Deleted aluminum oxide from composition .
05/23/02	2100-2.0000	Section 2: Discontinued & deleted Firetemp® TF; transferred CE and SE product names to new MSDS 2104. Revised composition for SI and CI. Updated Sect. 15 WHMIS: 1,2-propylene glycol not a controlled substance.

This is the end of MSDS # 2100